

KA SP 300 / 600 (-IP) EN 1.1

For further information
please visit our product-
website:

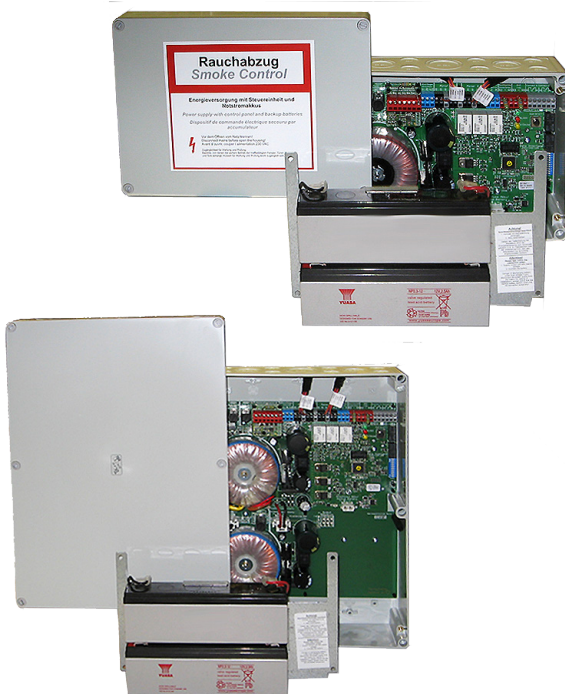

[short.simon-protec.com/
sheven](http://short.simon-protec.com/sheven)



Copyright by SIMON PROtec Systems GmbH
Subject to technical changes and errors. All figures are exemplary.



SIMON PROtec Systems GmbH • Medienstraße 8 • D-94036 Passau

+49 (0) 851 988 70-0 • +49 (0) 851 988 70-70 • info@simon-protec.com • www.simon-protec.com



**These operating instructions are only valid with the supplied
supplementary sheet „Safety instructions and Warranty conditions“!**

Table of contents

1. General	3
1.1. Preface to this quickguide.....	3
1.2. Use for intended purpose	3
1.3. SIMON LINK.....	3
2. Functional description	3
2.1. Power supply	3
2.2. Emergency power supply	3
2.3. Control electronics.....	3
2.4. Operating status indicators (OK, FAULT and ALARM)	3
3. Functions	4
3.1. Ventilation function.....	4
3.2. Gap ventilation.....	5
3.3. Automatic ventilation CLOSED (time-dependent)	5
3.4. Wind / Rain detector (WRD).....	5
3.5. Emergency button reset-/override function.....	5
3.6. External output of messages	5
4. Mounting	7
4.1. Mounting plastic housing	7
4.2. Electrical connection.....	8
4.3. FAS auto-reset function	10
4.4. Wire lengths.....	10
4.5. Motor cable monitoring by DD-100.....	10
5. Commissioning	11
5.1. Commissioning SP 300/600 plastic housing.....	11
5.2. Commissioning SP-300/600-AP steel-sheet housing.....	11
5.3. Troubleshooting	12
6. Technical Data	12

1. General

1.1. Preface to this quickguide

These instructions serve as a quick start guide for professional installation by trained, knowledgeable specialists (such as mechatronics engineers or electricians) and/or specialists with knowledge of electrical device installation.

The complete instructions can be found on our product website:

short.simon-protec.com/sheven

Please note the pin assignment, the minimum performance data (see Chapter 6 'Technical Data' on page 12) and the supplementary sheet 'Safety Instructions and Warranty Conditions' in all cases.

1.2. Use for intended purpose

See supplementary sheet "Safety instructions and Warranty conditions"!

1.3. SIMON LINK



INFORMATION



Functions that can be parameterised or activated with SIMON LINK are marked with the SIMON LINK logo! Further information about SIMON LINK can be found on our website.



short.simon-protec.com/slen

2. Functional description

SP 300/600 are control systems that are primarily used in staircases for smoke extraction and daily ventilation.

They enable the connection of

- smoke detectors,
- manual control devices, including those with three wires (for renovation/old buildings)
- fire alarm signals (FAS)

and the control of actuators.

It essentially consists of three components:

- power supply
- emergency power supply
- control electronics

2.1. Power supply

If the SP 300/600 is connected to the mains, it provides the maximum output via the power supply (mains-operation).

2.2. Emergency power supply

The emergency power supply of the SP 300/600 is ensured by two 12 V lead bat-teries.

2.3. Control electronics

The complete control of the SP 300/600 is handled by a microcontroller.

2.4. Operating status indicators (OK, FAULT and ALARM)

The SP 300/600 has three operational status indicators on the control board to display the current operation mode.

- Green LED: mains operation indication
- Yellow LED: status or fault indication
- Red LED: alarm indication

3. Functions

3.1. Ventilation function

In order to use the SP 300/600 for ventilation, ventilation OPEN/CLOSE switches can be connected.

Many different action behaviors can be allocated to the switches. (See table 1: Matrix ventilation switch on page 4).

Pressing both switches (OPEN/CLOSE) si-multaneously causes the function STOP. The ventilation function can only be controlled during mains operation.

Figure 1: DIP switch SW1

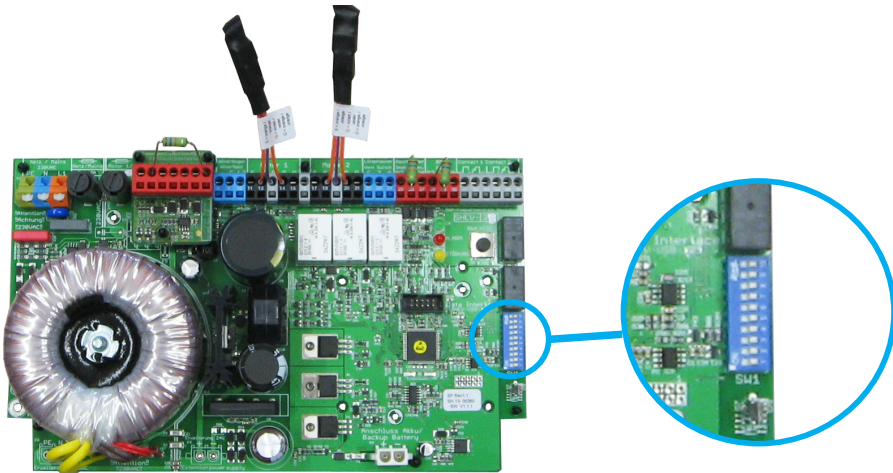

Table 1: Matrix ventilation switch

Con-fig.	SW1 - 1	SW1 - 2	SW1 - 3	SW1 - 4	Configuration ventilation switch	Remarks
1	OFF	OFF	OFF	OFF	Continuous OPEN/CLOSED	Delivery status
2	ON	OFF	OFF	OFF	OPEN and CLOSED with dead man function	Dead man function – the actuator run as long as the vent button is pressed in OPEN or CLOSE.
3	OFF	ON	OFF	OFF	OPEN with dead man function / CLOSED without	
4	ON	ON	OFF	OFF	OPEN without dead man function / CLOSED with	
5	OFF	OFF	ON	OFF	Gap ventilation	In case of ventilation the actuators open for the programmed time.
6	ON	OFF	ON	OFF	Automatic ventilation CLOSED	The system closes automatically after the expiration of the time.
7	OFF	ON	ON	OFF	Gap ventilation with automatic ventilation CLOSED	Combination of configuration 5 and 6
8	OFF	OFF	ON	ON	Programming mode for gap ventilation	
9	ON	OFF	ON	ON	Programming mode for automatic ventilation closed	
10	ON	ON	ON	ON	Ventilation switch closed	Ventilation disabled

3.2. Gap ventilation



Gap ventilation can be activated by setting DIP switch SW1 – 3 to ON.

This function is time controlled and factory-set to 3 seconds.



ATTENTION

Dead man function in the OPEN direction is inactive during limited ventilation.

3.3. Automatic ventilation CLOSED (time-dependent)



The automatic close function of the actuators after ventilation can be activated by setting DIP switches **SW1–1** and **SW1–3** to ON. This function time is controlled and factory-set to 10 minutes.

3.4. Wind / Rain detector (WRD)

If a wind / rain detector is installed and the SHEV 3 / 6 receives a signal from the wind / rain detector due to rainfall or strong winds (> 5 BF), it triggers the connected actuators auto-matically in closing direction.

3.5. Emergency button reset-/override function

The SHE-message can be reset by the emergency button. By pressing the CLOSE button for less than 5 seconds for the first time, an alarm CLOSE signal is sent (override). The visualisation of the alarm status is not changed.

By pressing the CLOSE button for at least 5 seconds, the alarm for the entire system is reset (reset with CLOSE movement), provided there are no other alarm messages (e.g. smoke detector, fire alarm system).

3.6. External output of messages

The SHEV 3 / 6 is equipped with two volt-free relays or contacts for redirecting of fault or other messages. They can be allocated freely using DIP switches 5-8 at SW1 (see table 2 on page 6).

Functions

Table 2: Matrix Melderelais (C1, C2)

SW1 - 5	SW1 - 6	SW1 - 7	SW1 - 8	Allocation C1	Allocation C2	Remarks
OFF	OFF	OFF	OFF	Message SHE alarm	OK	Delivery state
ON	OFF	OFF	OFF	Message SHE alarm	Actuators triggered in OPENING direction	
OFF	ON	OFF	OFF	Message SHE alarm	Actuators triggered in CLOSING direction	
ON	ON	OFF	OFF	Message SHE alarm	Wind / rain detector „CLOSING active“	
OFF	OFF	ON	OFF	Message SHE alarm	OK	Power supply OK and no wire break on motor lines 1/2
ON	OFF	ON	OFF	OK	Actuators triggered in OPENING direction	
OFF	ON	ON	OFF	OK	Actuators triggered in CLOSING direction	
ON	ON	ON	OFF	OK	Wind / rain detector „CLOSING active“	
OFF	OFF	OFF	ON	OK	OK	Power supply OK and no wire break on motor lines 1/2
ON	OFF	OFF	ON	Actuators triggered in OPENING direction	Actuators triggered in CLOSING direction	
OFF	ON	OFF	ON	Actuators triggered in OPENING direction	Wind / rain detector „CLOSING active“	
ON	ON	OFF	ON	Actuators triggered in OPENING direction	OK	Power supply OK and no wire break on motor lines 1/2
OFF	OFF	ON	ON	Actuators triggered in CLOSING direction	Wind / rain detector „CLOSING active“	
ON	OFF	ON	ON	Actuators triggered in CLOSING direction	OK	Power supply OK and no wire break on motor lines 1/2
OFF	ON	ON	ON	Wind / rain detector „CLOSING active“	OK	Power supply OK and no wire break on motor lines 1/2
ON	ON	ON	ON	Meldung RWA ausgelöst	Message FAS fire alarm	

Mounting

4. Mounting

ATTENTION

Observe the instructions in the supplementary sheet „Safety instructions and warranty conditions“ under all circumstances!

ATTENTION

The openings of the battery cells (round lids on top of the batteries) must not point downwards. This may cause a leak out of the battery!

ATTENTION

Do NOT connect the battery during installation!

4.1. Mounting plastic housing

Figure 2: Mounting points SP 300 plastic housing (SP 600 analog)

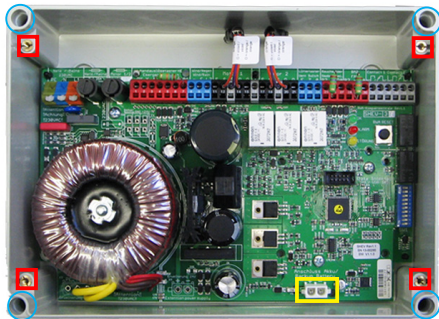

Figure 3: Mounting points SP 300-AP steel-sheet housing (SP 600 analog)

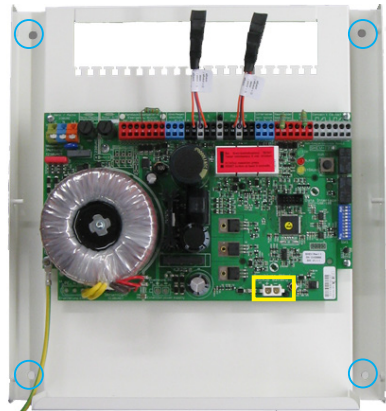





Figure 4: Mounting points SP 300-IP (SP 600 analog)



-  Mounting points housing
-  Mounting points batteries
-  Battery port

Mounting

4.2. Electrical connection



DANGER

Disconnect the power supply chord for all poles from mains. The connection of the SHEV 3 / 6 must be done volt-free!

Figure 5: Wiring diagram complete (simplified illustration)

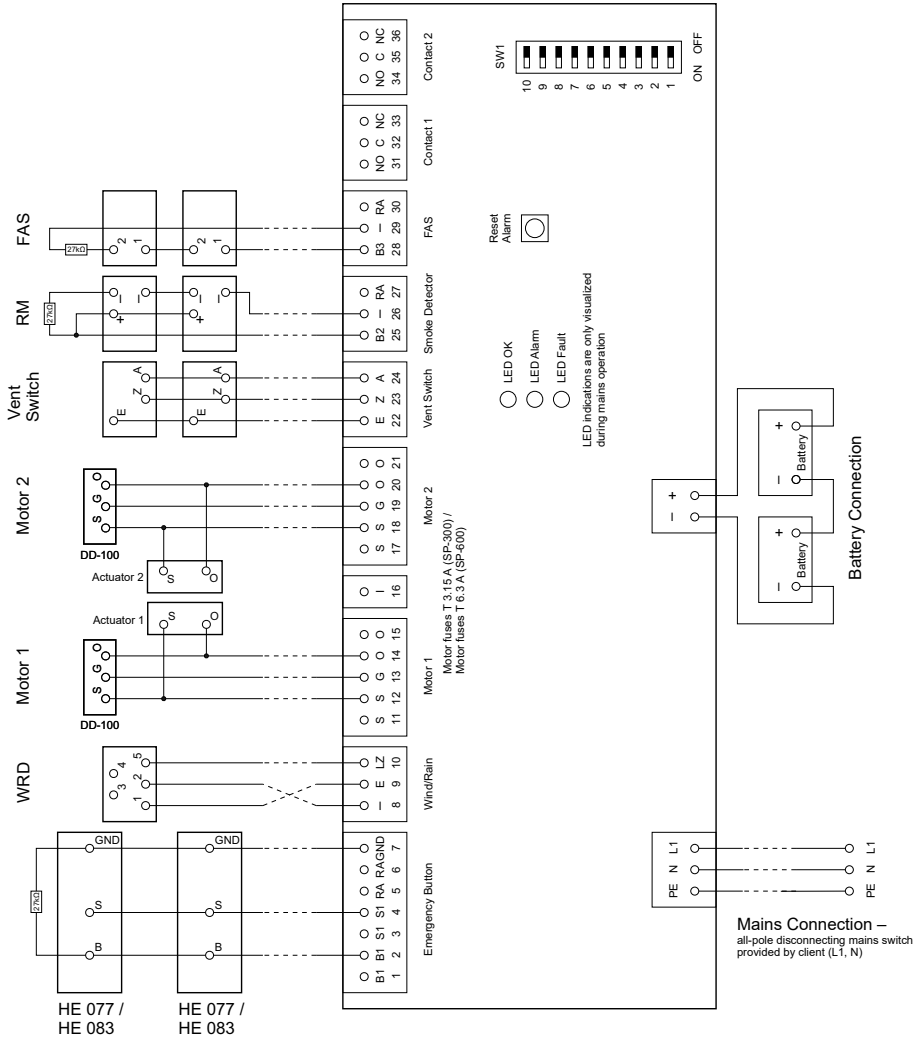

Mounting



INFORMATION

For the detection lines, the use of shielded cables is recommended.

Figure 6: Wiring diagram emergency button HE 083

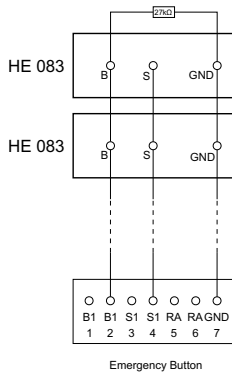

INFORMATION

A maximum of two emergency switches are allowed.

Figure 7: Wiring diagram wind / rain detector

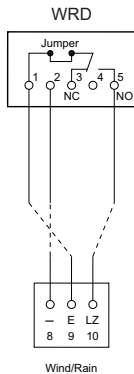

Figure 8: Wiring diagram ventilation button

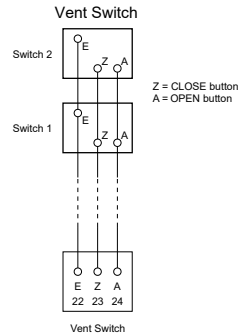
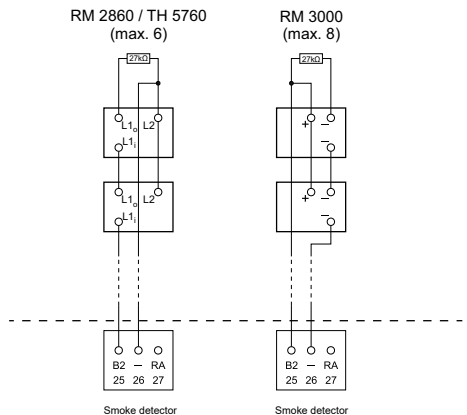

Figure 9: Wiring diagram smoke detector



Mounting

Figure 10: Wiring diagram thermostat

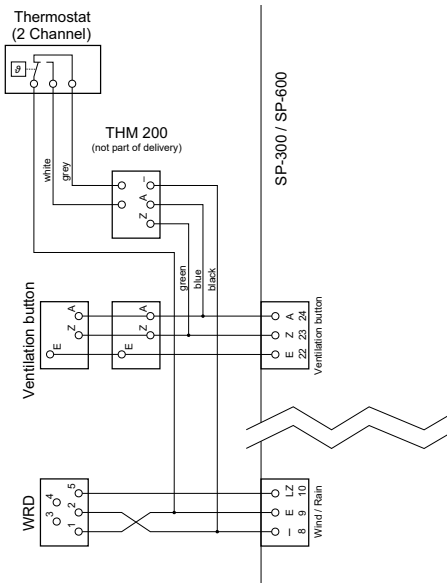
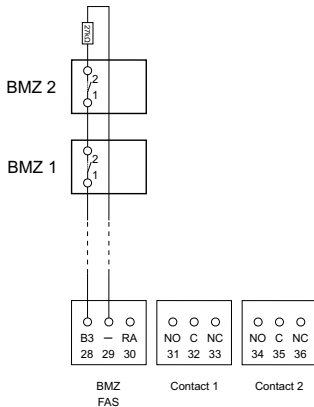

Figure 11: Wiring diagram contact FAS



4.3. FAS auto-reset function

Generally, all SHEV alarms must be reset manually by pressing the reset button (on-board/ EOS). For detection line 3 (FAS / fire alarm system), the Auto-RESET function can be activated which, after resetting the FAS, also resets the SP control center and controls the motor outputs to CLOSED.

Setting: DIP switch **SW1 – 10 to ON**.

4.4. Wire lengths



INFORMATION

Dimension indications (rule of thumb):

Wire cross-section [mm²] = wire length [m]

x number of motors

x power input per Motor [A] / 70

The regulations of DIN VDE 0100 and DIN VDE 0298 continue to apply.

4.5. Motor cable monitoring by DD-100

The EOL diode terminators DD-100 are for the cable monitoring of the motor outputs. They need to be installed in the junction box of the last actuator.

5. Commissioning

ATTENTION

Only after the SP 300/600 has been commissioned successfully and the permanent on-site mains power supply is ensured the battery may be installed and connected.

INFORMATION

If the battery is disconnected, the error message may appear after at least 8 minutes (green LED flashes, yellow LED lights up).

ATTENTION

Only batteries approved by the panel manufacturer are allowed for connection. If any other battery is used, the control panel loses the relevant certifications and the warranty expires.

5.1. Commissioning SP 300/600 plastic housing

- Connect battery plug to port „Battery back-up“ (see figs. 2 and 3 on page 6)
- Fasten the battery with 4 screws M4 x 8 mm (screws are included in the scope of delivery)

5.2. Commissioning SP-300/600-AP steel-sheet housing

- Place the battery pack on the battery panel of the housing
- Connect battery plug to port „Battery back-up“

Figure 12: Battery connection SP 300-AP steel sheet housing (SP 600 analog)

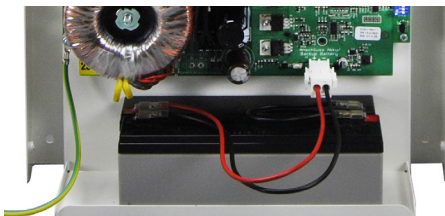

ATTENTION

After connecting the battery pack, press the RESET button for 5 seconds in order to initialize the SP 300/600!

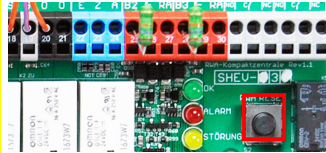

- Connect the PE cable to the PE-connection on the lid.

Figure 13: PE connection

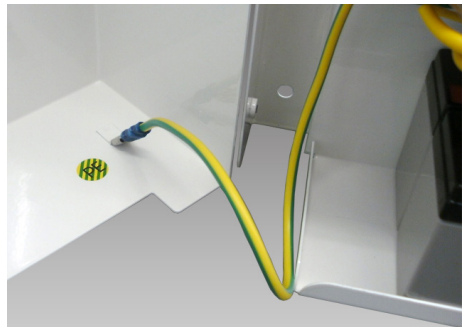

- Place the cover and fasten it with the two screws on the side.



Technical Data

5.3. Troubleshooting



ATTENTION

Due to the low loop current, the insulation resistance of the monitored wires (B1, B2 and B3) must be checked! The insulation resistance must be > 20 MΩ/km (manufacturer information), otherwise wire interruptions will no longer be detected reliably.



INFORMATION

The operating status of the SHEV 3/6 RSV can optionally be visualized with SIMON LINK (only during mains operation).

For more information visit

short.simon-protect.com/slen



6. Technical Data

Table 3: Electrical characteristics

Power supply information	
Nominal voltage	230 VAC
Acceptable voltage range	195 VAC to 264 VAC
Power consumption ⁽¹⁾	0.56 A (SP 300) 1.20 A (SP 600)
Min. series fuse (on-site)	≥ C 16 A
Connected load	103 VA (SP 300) 206 VA (SP 600)
Inrush current	approx. 10 A (SP 300) approx. 20 A (SP 600)
Frequency range	47 Hz to 63 Hz
Mains fuse (internal)	Fuse characteristic: Type T 1.25 A
Clamp format	0.5 mm ² – 2.5 mm ²
Out information motor channels	
Duty cycle (D)	ED 30%
Output voltage mains operation (nominal)	24 VDC
Voltage range (mains operation)	23.0 VDC to 24.5 VDC
Output voltage battery operation (nominal)	24 VDC
Voltage range (battery operation)	21 VDC to 28.6 VDC
Output current (I _{out}) (short-term operation) (I _{out} = I _{mot1} + I _{mot2})	3 A (SP 300) 6 A (SP 600)
Power output (non-stop operation)	50 W (SP 300) 100 W (SP 600)
Power output (short-term operation)	73.5 W (SP 300) 145 W (SP 600)
Output fuse for actuators	Fuse characteristics: Type T 3.15 A (SP 300) Type T 6.3 A (SP 600)
Ripple of the output voltage V _{pp} (0 A < I _{out} < 3 A bzw. 0 A < I _{out} < 6 A)	≤ 50 mVpp
Power outage bridge-over time	10 ms
Clamp format	0.5 mm ² – 2.5 mm ²
Functional safety in case of power failure	72 hours

(1) Power consumption at maximum load of the supply system.

Technical Data

Table 4: Connection

Connection information emergency switches (HE 083)		
Maximum number of main emergency switches (i.e. HE 083)		2
Output voltage range (B1)	Clamp 7	17.5 VDC to 18 VDC
Connection fire alarm system (FAS)		
Output voltage range (B3)	Clamp 28	17.5 VDC to 18 VDC
Reset time after SHEV reset (by disconnecting from mains B3)	Clamp 28	3 s
Connection information smoke detector (RM 3000 / RM 2860)		
Maximum number		8 x RM 3000 6 x RM 2860
Output voltage range (B2)	Clamp 25	17.5 VDC to 18 VDC
Connection information wind / rain detector (WRD)		
Maximum number		1
The connection of the wind / rain detector (WRD) is deactivated in emergency power operation.		
Output voltage range (E)	Clamp 9	23.0 VDC to 24.5 VDC
Current carrying capacity (E)	Clamp 9	max. 150 mA
Connection information ventilation switch		
Output voltage range (E)	Clamp 22	23.0 VDC to 24.5 VDC
Connection information free input		
Input voltage range (I)	Clamp 16	DO NOT USE!
Connection information volt-free contacts (NO-C-NC)		
Voltage and current rating of the switching contacts 1 and 2	Clamp 32 to 31/33 Clamp 35 to 34/46	max. 30 VDC 2 A DC (60 W / 62.5 VA)

Table 5: Mechanical characteristics

Characteristic	Plastic housing SP-300/600	Steel-sheet housing SP-300/600-IP
Size (w x h x d)	254 x 180 x 111 mm (SP 300) 254 x 361 x 111 mm (SP 600)	325 x 305 x 90 mm (SP 300 IP) 325 x 423 x 89 mm (SP 600 IP)
Weight (incl. battery)	4.40 kg (SP 300) 6.40 kg (SP 600)	5.30 kg (SP 300 IP) 8.90 kg (SP 600 IP)
Protection type	IP66 ⁽¹⁾ acc. to EN 60529	IP54 acc. to EN 60529
Housing	Polystyrol Halogen-free	Steel-sheet (powder-coated)
Protection class	II	I ⁽²⁾
Colour	grey	RAL 9010

(1) With respective use of IP66 cable lead-through.

(2) The protective conductor is used as a functional conductor for a higher EMC immunity and should therefore be connected.

Technical Data

Table 6: Connection and operation

Connection	See figure 5 „Wiring diagram complete (simplified illustration)“ on page 7.
Terminal clamps	Tension spring clamps 0.5 mm ² – 2.5 mm ²
Deadlock according to prEN 12101-9	Optional; factory setting: On
Maximum wire length between control unit and actuator	See chapter 4.4 „Wire lengths“ on page 10.
Pause time during change of direction	200 ms
Maintenance	See supplementary sheet „Safety instructions and warranty conditions“

Table 7: Installation and environmental requirements

Operating temperature	-5 to 40° C ¹
Storage temperature	
Suitable for outdoor installation	No

(1) This temperature range applies to all components of the SP 300/600 system (including the battery).

Table 8: Approvals and certificates

EN-compliant	As per EMC-directive 2004 / 108 / EC and the low-voltage directive 2006 / 95 / EC
--------------	---

Table 9: Control time of inputs

Input digital (RZ. RA. LZ. Z. A)	500 ms
Inputs analog (B1. B2. B3) during mains operation	500 ms
Inputs analog (B1. B2. B3) during emergency power operation	2500 ms

Table 10: Lead battery

Maintenance-free lead battery	
Size (w x d x h)	178 x 34 x 64
Weight	2 x 0.95 kg
VdS registration	G101139 (Yuasa) / G122013 (SIMON)
Output voltage per battery	10.5 VDC to 14.1 VDC
Output voltage total (series connection)	21.0 VDC to 28.2 VDC
Rated capacity (total)	2.3 Ah
Service life	approx. 4 years